



## 10000 Series

Double Ported  
Globe Valves



# Dresser Masoneilan 10000 Series

## Double Ported Globe Valves

## Table of Contents

Features .....	1	C <sub>v</sub> and F <sub>L</sub> Versus Travel .....	5
Numbering System .....	2	Materials of Construction .....	7
General Data .....	2	Valve Dimensions .....	13
Temperature Range / Seat Leakage .....	3	Valve Weights .....	15
Ratings / Connections .....	4	Actuator Dimensions and Weights .....	16
Flow Coefficient - Rated C <sub>v</sub> .....	4	Sales Offices .....	Back Cover

## Features

The 10000 Series double seated control valves are semi-balanced designs, providing high allowable pressure drops, reduced actuator thrust requirements, and large flow areas to effectively handle dirty fluid applications. Standard features include:

### Excellent Performance & Reliability

Separate top and bottom guides in the Masoneilan 10000 Series provide heavy duty plug and stem support throughout the valve stroke range. This results in excellent throttling control characteristics and high product reliability.

### High Pressure Drop Capability

The 10000 Series offers a semi-balanced trim construction, which allows for application in higher pressure drop applications using standard actuation. This also helps to reduce product complexity and overall assembly size and weight.

### Dirty Service Design

Large flow areas within the 10000 Series design, makes it an excellent choice for applications involving dirty fluids. Foreign particles can pass through the valve without negatively affecting control performance.

### Easy Field Maintenance

The 10000 Series is designed for top and bottom entry, allowing for quick access to the key trim and soft good components. This also permits easy access to the top and bottom guides for repair or replacement.

### Reduced Emissions

The 10000 Series can be supplied with the Masoneilan LE Packing design to provide low emissions performance meeting various environmental regulations worldwide.

### NACE Compliance

Construction for Sour Service Applications in accordance with NACE standard MR 0103 is readily available. Applications requiring compliance to MR 0175, 2003 Rev or ISO 15156 can also be provided.

# Numbering System

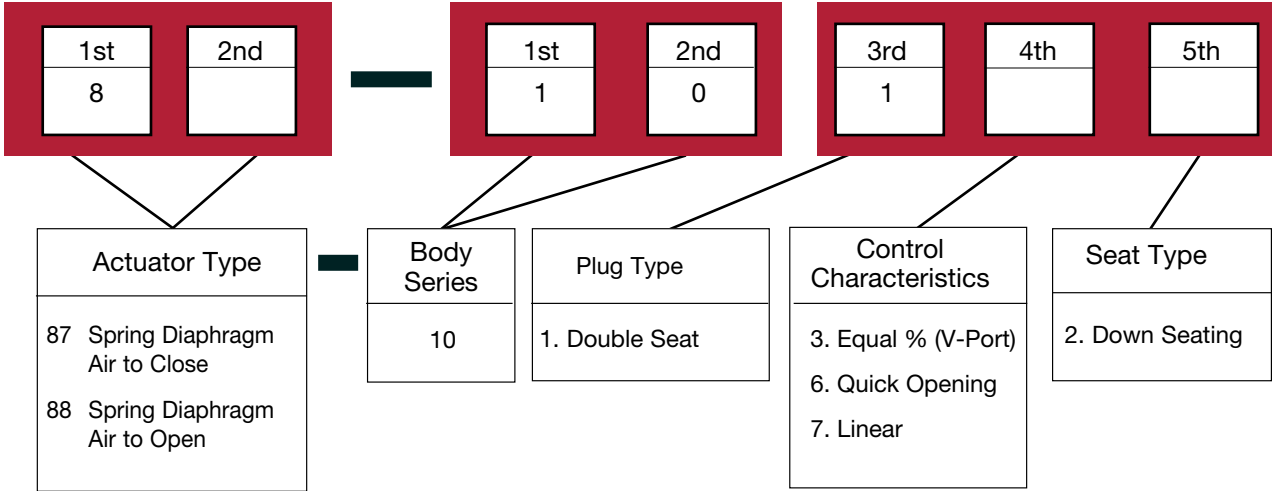

# General Data

- **Flow Direction**  
 All trim: Flow through both ports
- **Body**  
 Type: Double seat globe
- **Body Bonnet & Lower Flange**  
 Type: Bolted
- **Bonnet & Lower Flange**  
 Materials: Carbon steel  
               Stainless steel  
               Chrome-molybdenum steel
- **Trim**  
 Plug type: Double seat  
               V-port or contoured  
 Seat ring: Threaded  
 Guide: Heavy top and bottom guiding  
 Capacity: Full area  
               Reduced capacity (0.4 factor)  
 Cv ratio: 50:1  
 Flow characteristics: Equal percentage  
                               Quick opening  
                               Linear
- **Actuator**  
 Type: Spring diaphragm  
 Handwheel: Optional

# Temperature Range / Seat Leakage





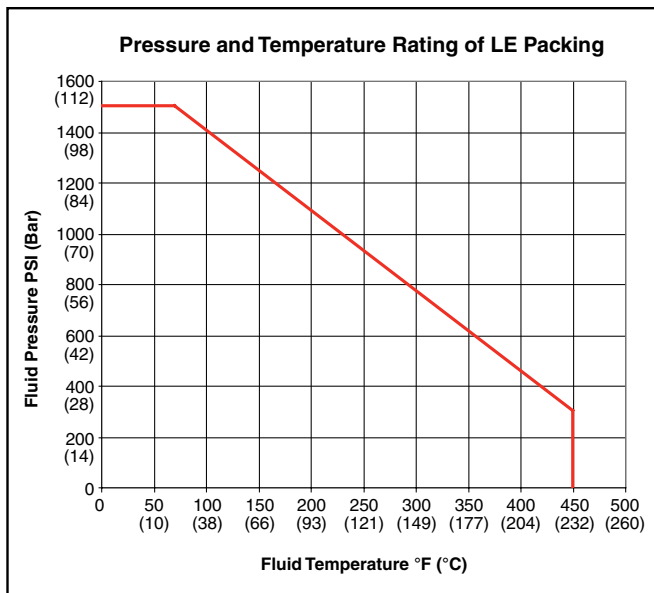



































































Valve Size <sup>(1)</sup>		Body Rating	Body & Bonnet Material	Temperature Range				Seat Leakage IEC 60534-4 and ANSI/FCI 70.2 Class
				Standard Bonnet		Extension Bonnet		
inch	mm			min.	max.	min.	max.	
0.75 to 16	20 to 400	ASME Class 150 to 600 (PN 20 to 100)	Carbon Steel	-4°F (-20°C)	+450°F <sup>(1)</sup> (+232°C)	-4°F (-20°C)	+800°F (+427°C)	II
			Stainless Steel	-20°F (-29°C)	+450°F <sup>(1)</sup> (+232°C)	-148°F (-100°C)	+800°F (+427°C)	
			Chrome-Moly	32°F (0°C)	+450°F <sup>(1)</sup> (+232°C)	32°F (0°C)	+800°F (+427°C)	
			NACE	-4°F (-20°C)	+450°F (+232°C)			

- 1) Maximum temperature shown is with PTFE packing and LE Packing. Extended max. operating temperature of 800°F (427°C) allowable with Graphite packing.
- 2) LE Packing for low emissions applications is limited to maximum pressure and temperature as shown in chart below.



# Ratings / Connections

 RF Flanged    
  RT Joint    
  n Butt Weld    
  n Socket Weld    
  n Threaded

Valve Size		ASME Class		
Inch	mm	150	300	600
.75	20	  n n	  n n	  n n
1	25	  n n	  n n	  n n
1.5	40	  n n	  n n	  n n
2	50	  n n	  n n	  n n
3	80	  Δ	  Δ	  Δ
4	100	  Δ	  Δ	  Δ
6	150	  Δ	  Δ	  Δ
8	200	  Δ	  Δ	  Δ
10	250	  Δ	  Δ	  Δ
12	300	  Δ	  Δ	  Δ
14	350	  Δ	  Δ	  Δ
16	400	  Δ	  Δ	  Δ

1) Consult factory for availability of additional sizes and end connections.

## Flow Coefficient – Rated $C_v$

Nominal Size		Travel		Full Capacity $C_v^{(1)}$	Reduced Capacity $C_v$
Inch	mm	Inch	mm		
.75	20	0.5	12.7	8	-
1	25	0.5	12.7	12	8 <sup>(2)</sup>
1.5	40	0.8	20.3	28	11
2	50	0.8	20.3	48	19
3	80	1.5	38.1	110	44
4	100	1.5	38.1	195	78
6	150	2	50.8	450	180
8	200	2.5	63.5	750	300
10	250	2.5	63.5	1160	460
12	300	3.5	88.9	1620	650
14 <sup>(3)</sup>	350	4	101.6	2000 <sup>(4)</sup>	-
16	400	4	101.6	2560 <sup>(4)</sup>	-

- 1) Rated  $C_v$  for Quick Opening trim is 1.3 times values shown.
- 2) 1" size reduced capacity trim is same as .75" size full area trim.
- 3) Consult factory for details on 14" size.
- 4) 14" and 16" sizes are only available with Equal Percentage trim.

# C<sub>V</sub> and F<sub>L</sub> versus Travel

Contoured Trim

ASME Class 150 to 600

Flow Characteristic: LINEAR

Percent of Travel			10	20	30	40	50	60	70	80	90	100
F <sub>L</sub>	Full Area		.63	.64	.65	.70	.77	.85	.90	.90	.89	.88
	Reduced Area		.63	.64	.65	.70	.75	.80	.82	.82	.81	.80
Valve Size	Orifice Diameter	Travel	Rated C <sub>V</sub>									
inch	inch	inch										
0.75	.88/.80	0.5	.8	1.6	2.4	3.2	4.0	4.8	5.6	6.4	7.2	8
1	.88/.80	0.5	.8	1.6	2.4	3.2	4.0	4.8	5.6	6.4	7.2	8
	1.06/.98	0.5	1.2	2.4	3.6	4.8	6	7.2	8.4	9.6	10.8	12
1.5	1.06/.98	0.8	1.1	2.2	3.3	4.4	5.5	6.6	7.7	8.8	9.9	11
	1.5/1.42	0.8	2.8	5.6	8.4	11.2	14	16.8	19.6	22.4	25.2	28
2	1.43/1.35	0.8	1.9	3.8	5.7	7.6	9.5	11.4	13.3	15.2	17.1	19
	2.00/1.90	0.8	4.8	9.6	14.4	19.2	24	28.8	33.6	38.4	43.2	48
3	1.87/1.78	1.5	4.4	8.8	13.2	17.6	22	26.4	30.8	35.2	39.6	44
	2.62/2.53	1.5	11	22	33	44	55	66	77	88	99	110
4	2.37/2.28	1.5	7.8	15.6	23.4	31.2	39	46.8	54.6	62.4	70.2	78
	3.50/3.40	1.5	19.5	39	58.5	78	97.5	117	136	156	175	195
6	3.50/3.40	2	18	36	54	72	90	108	126	144	162	180
	5.25/5.15	2	45	90	135	180	225	270	315	360	405	450
8	4.62/4.53	2.5	30	60	90	120	150	180	210	240	270	300
	7.00/6.87	2.5	75	150	225	300	375	450	525	600	675	750
10	5.25/5.15	2.5	46	92	138	184	230	276	322	368	414	460
	8.75/8.62	2.5	116	232	348	464	580	696	812	928	1044	1160
12	6.37/6.25	3.5	65	130	195	260	325	390	455	520	585	650
	10.50/10.34	3.5	162	324	486	648	810	972	1134	1296	1458	1620

# C<sub>V</sub> and F<sub>L</sub> versus Travel

V-Port Trim

ASME Class 150 to 600

Flow Characteristic: EQUAL PERCENTAGE

Percent of Travel			10	20	30	40	50	60	70	80	90	100
F <sub>L</sub>	Full Area		.96	.96	.96	.96	.95	.94	.94	.93	.91	.90
	Reduced Area		.96	.96	.95	.94	.93	.92	.91	.90	.89	.88
Valve Size	Orifice Diameter	Travel	Rated C <sub>V</sub>									
inch	inch	inch										
0.75	.88/.80	0.5	.24	.48	.64	.88	1.2	1.8	2.3	3.6	5.2	8
1	.88/.80	0.5	.24	.48	.64	.88	1.2	1.8	2.3	3.6	5.2	8
	1.06/.98	0.5	.36	.72	.96	1.3	1.8	2.6	3.5	5.4	7.8	12
1.5	1.06/.98	0.8	.33	.66	.88	1.2	1.6	2.4	3.2	4.9	7.1	11
	1.5/1.42	0.8	.84	1.7	2.2	3.1	4.2	6.2	8.1	12.6	18.2	28
2	1.43/1.35	0.8	0.6	1.1	1.5	2	2.8	4.2	5.5	8.5	12.3	19
	2.00/1.90	0.8	1.4	2.8	3.8	5.3	7.2	10.5	13.9	21.6	31.2	48
3	1.87/1.78	1.5	1.3	2.6	3.5	4.8	6.6	9.7	12.8	19.8	28.6	44
	2.62/2.53	1.5	3.3	6.6	8.8	12.1	16.5	24.2	31.9	49.5	71.5	110
4	2.37/2.28	1.5	2.3	4.7	6.2	8.6	11.7	17.2	22.6	35.1	50.7	78
	3.50/3.40	1.5	5.8	11.7	15.6	21.4	29.2	42.9	56.5	87.7	126	195
6	3.50/3.40	2	5	11	14	20	27	40	52	81	117	180
	5.25/5.15	2	14	27	36	50	68	99	130	202	292	450
8	4.62/4.53	2.5	9	18	24	33	45	66	87	135	195	300
	7.00/6.87	2.5	23	45	60	83	112	165	217	337	487	750
10	5.25/5.15	2.5	14	28	37	51	69	101	133	207	299	460
	8.75/8.62	2.5	35	70	93	127	174	255	336	522	754	1160
12	6.37/6.25	3.5	20	39	52	72	98	143	189	293	423	650
	10.50/10.34	3.5	49	97	130	178	243	356	469	729	1053	1620
14	12.2/12.1	4	60	120	160	220	300	440	580	900	1300	2000
16	14.00/13.86	4	77	153	207	281	384	563	742	1152	1664	2560



# Materials of Construction

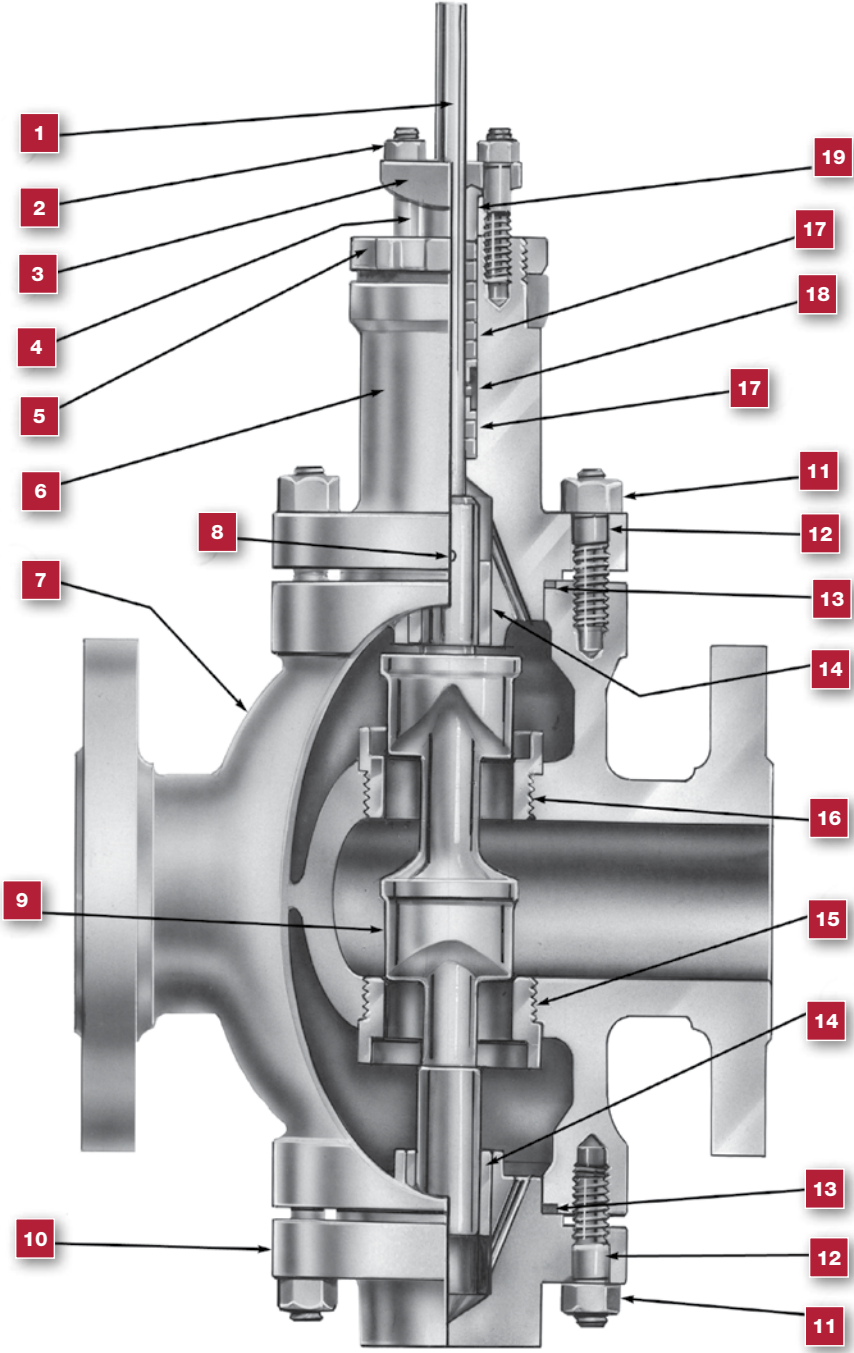

# Materials of Construction

Standard Carbon Steel Version

Ref. No.	Temperature Range	-4°F		650°F		800°F		
		Description		Materials				
1	Plug Stem	316 St. St. ASTM 479 TY 316						
2	Packing Flange Nut	St. St. ASTM A194 GR 8						
3	Packing Flange	Zinc Dichromate Carbon Steel ASTM A105						
4	Packing Flange Stud	304 St. St. ASTM A193 GR B8						
5	Drive Nut	Carbon Steel SAE 1117 or ASTM A216 GR WCC						
6	Valve Bonnet	Carbon Steel ASTM A216 Grade WCC or ASTM A105						
7	Valve Body	Carbon Steel ASTM A216 Grade WCC						
8	Plug Pin	316 St. St. ASTM 479 TY 316						
9	Plug	316 St. St. ASTM 479 TY 316			316 St. St. with Hardfaced Seat and Guide			
		316 St.St.with Hardfaced Seat						
10	Lower Flange	Carbon Steel ASTM A216 Grade WCC or ASTM A105						
11	Body Stud Nut	Carbon Steel ASTM A194 GR 2H						
12	Body Stud	Alloy Steel ASTM A193 GR B7						
13	Body Gasket	316L St. St. w/Flexible Graphite Filler (Spiral Wound)						
14	Guide Bushing	440C St. St. ASTM A276 TY 440C			Stellite 6 UNS 30006			
		316 St. St. ASTM 479 TY 316			316 St. St. with Hardfaced Seat			
15	Lower Seat Ring	316 St.St. with Hardfaced Seat						
		316 St. St. ASTM 479 TY 316			316 St. St. with Hardfaced Seat			
16	Upper Seat Ring	316 St.St. with Hardfaced Seat						
		316 St. St. ASTM 479 TY 316						
18	Lantern Ring (Optional)	Austenitic 300 Series Stainless Steel						
19	Packing Follower	Austenitic 300 Series Stainless Steel						
Ref. No.	Temperature Range	-20°C		343°C		427°C		

# Materials of Construction

Standard Stainless Version

Ref. No.	Temperature Range	-148°F		-20°F		650°F		800°F		
		Description		Materials						
1	Plug Stem	316 St. St. ASTM 479 TY 316								
2	Packing Flange Nut	St. St. ASTM A194 GR 8								
3	Packing Flange	Zinc Dichromate Carbon Steel ASTM A105								
4	Packing Flange Stud	304 St. St. ASTM A193 GR B8								
5	Drive Nut	Carbon Steel SAE 1117 or ASTM A216 GR WCC								
6	Valve Bonnet Plain Version		316 Stainless Steel ASTM A351 Grade CF8M or ASTM A182 Grade F316							
6	Valve Bonnet Extended Version	316 Stainless Steel ASTM A351 Grade CF8M or ASTM A182 Grade F316								
7	Valve Body	316 Stainless Steel ASTM A351 Grade CF8M								
8	Plug Pin	316 St. St. ASTM 479 TY 316								
9	Plug	316 St. St. ASTM 479 TY 316				316 St. St. with Hardfaced Seat and Guide				
		316 St.St. with Hardfaced Seat								
10	Lower Flange	316 Stainless Steel ASTM A351 Grade CF8M or ASTM A182 Grade F316								
11	Body Stud Nut		Carbon Steel ASTM A194 GR 2H Zinc Dichromate Plating				C. S. ASTM A194 GR 2H (No Zinc)			
		ASTM A194 Gr. 8 <sup>(1)</sup>								
12	Body Stud		Alloy Steel ASTM A193 GR B7 Zinc Dichromate Plating				Alloy Steel ASTM A193 GR B7 <sup>(3)</sup>			
		ASTM A193 Gr. B8 <sup>(1)(3)</sup>								
13	Body Gasket	316L St. St. w/Flexible Graphite Filler (Spiral Wound)								
14	Guide Bushing	Stellite 6 <sup>(2)</sup>								
15	Lower Seat Ring	316 St. St. ASTM 479 TY 316				316 St. St. with Hardfaced Seat				
		316 St.St. with Hardfaced Seat								
16	Upper Seat Ring	316 St. St. ASTM 479 TY 316				316 St. St. with Hardfaced Seat				
		316 St.St. with Hardfaced Seat								
18	Lantern Ring (Optional)	Austenitic 300 Series Stainless Steel								
19	Packing Follower	Austenitic 300 Series Stainless Steel								
Ref. No.	Temperature Range	-100°C		-29°C		343°C		427°C		

1) Use of non-plated bolting must be reviewed by the factory for proper application.

2) For operating temperatures above 650°F (343°C), the Solid Stellite bushings are tack welded to the bonnet and lower flange to account for thermal expansion.

3) ASTM A453 Gr. 660 may be required to meet low temperature or corrosion resistance requirements.

# Materials of Construction

Standard Chrome-Moly Version

Ref. No.	Temperature Range		-32°F	650°F	800°F
	Description		Materials		
1	Plug Stem		316 St. St. ASTM 479 TY 316		
2	Packing Flange Nut		St. St. ASTM A194 GR 8		
3	Packing Flange		Zinc Dichromate Carbon Steel ASTM A105		
4	Packing Flange Stud		304 St. St. ASTM A193 GR B8		
5	Drive Nut		Carbon Steel SAE 1117 or ASTM A216 GR WCC		
6	Valve Bonnet		Chrome-Molybdenum Steel ASTM A217 Grade WC9		
7	Valve Body		Chrome-Molybdenum Steel ASTM A217 Grade WC9		
8	Plug Pin		316 St. St. ASTM 479 TY 316		
9	Plug		316 St. St. ASTM 479 TY 316	316 St. St. with Hardfaced Seat and Guide	
			316 St. St. with Hardfaced Seat		
10	Lower Flange		Chrome-Molybdenum Steel ASTM A217 Grade WC9		
11	Body Stud Nut		Carbon Steel ASTM A194 GR 2H		
12	Body Stud		Alloy Steel ASTM A193 GR B7		
13	Body Gasket		316L St. St. w/Flexible Graphite Filler (Spiral Wound)		
14	Guide Bushing		440C St. St. ASTM A276 TY 440C	Stellite 6 UNS 30006	
15	Lower Seat Ring		316 St. St. ASTM 479 TY 316	316 St. St. with Hardfaced Seat	
			316 St. St. with Hardfaced Seat		
16	Upper Seat Ring		316 St. St. ASTM 479 TY 316	316 St. St. with Hardfaced Seat	
			316 St. St. with Hardfaced Seat		
18	Lantern Ring (Optional)		Austenitic 300 Series Stainless Steel		
19	Packing Follower		Austenitic 300 Series Stainless Steel		
Ref. No.	Temperature Range		0°C	343°C	427°C

Standard Chrome-Moly Version

Ref. No.	Temperature Range		-20°F	450°F	800°F
	Description		Materials		
17	Packing	Standard Bonnet	PTFE Packing		
			LE® Packing		
			Grafoil + Graphite wiper rings		
	Packing	Extension Bonnet	PTFE Packing		
LE® Packing					
Ref. No.	Temperature Range		-29°C	232°C	427°C

# Materials of Construction

NACE Materials Construction

Ref. No.	Temperature Range	-20°F	450°F
	Description	Standard and Optional Materials <sup>(1)</sup>	
1	Plug Stem	316 St. St. ASTM A479 TY 316 (HRC 22 Max.)	
		ASTM A638 Gr 660 <sup>(2)</sup>	
2	Packing Flange Nut	304 St. St. ASTM A194 Gr 8 <sup>(3)</sup> (non exposed)	
		Alloy Steel ASTM A194 Gr 8A <sup>(4)</sup> (exposed)	
3	Packing Flange	<i>Zinc Dichromate Carbon Steel ASTM A105</i>	
4	Packing Flange Stud	304 St. St. ASTM A193 GR B8 (exposed and non exposed)	
5	Drive Nut	Carbon Steel SAE 1117 <sup>(3)</sup>	
		Carbon Steel ASTM A105 or SAE 1010-1025 <sup>(4)</sup>	
6	Valve Bonnet	<i>Carbon Steel ASTM A216 Grade WCC (HRC 22 Max.)</i>	
		<i>Carbon Steel ASTM A105 (HRC 22 Max.)</i>	
		<i>316 St. St. ASTM A351 Gr CF8M (HRC 22 Max.)</i>	
7	Valve Body	<i>Carbon Steel ASTM A216 Grade WCC (HRC 22 Max.)</i>	
		<i>316 St. St. ASTM A351 Gr CF8M (HRC 22 Max.)</i>	
8	Plug Pin	316 St. St. ASTM A479 TY 316 (HRC 22 Max.)	
9	Plug	316 St. St. ASTM A479 TY 316 (HRC 22 Max.)	
		316 St. St. ASTM A479 TY 316 with Hardfaced Seat (HRC 22 Max.)	
10	Lower Flange	<i>Carbon Steel ASTM A216 Grade WCC (HRC 22 Max.)</i>	
		<i>Carbon Steel ASTM A105 (HRC 22 Max.)</i>	
		<i>316 St. St. ASTM A351 Gr CF8M (HRC 22 Max.)</i>	
11	Body Stud Nut	ASTM A194 GR 2H <sup>(3)</sup> (non exposed)	
		ASTM A194 Gr 2HM <sup>(4)</sup> (exposed)	
		ASTM A194 GR 2H Zinc Plating <sup>(3)(5)</sup> (non exposed)	
		ASTM A194 Gr 2HM Zinc Plating <sup>(4)(5)</sup> (exposed)	
12	Body Stud	ASTM A193 GR B7 <sup>(3)</sup> (non exposed)	
		ASTM A193 Gr B7M <sup>(4)</sup> (exposed)	
		ASTM A193 GR B7 Zinc Plated <sup>(3)(5)</sup> (non exposed)	
		ASTM A193 Gr B7M Zinc Plated <sup>(4)(5)</sup> (exposed)	
13	Body Gasket	316L St. St. w/Flexible Graphite Filler (Spiral Wound)	
14	Guide Bushing	Stellite 6 UNS 30006	
Ref. No.	Temperature Range	-29°C	232°C

# Materials of Construction

## NACE Materials Construction

Ref. No.	Temperature Range	-20°F	450°F
	Description	Standard and Optional Materials <sup>(1)</sup>	
15	Lower Seat Ring	316 St. St. ASTM A479 TY 316 (HRC 22 Max.)	
		316 St. St. ASTM A479 TY 316 with Hardfaced Seat (HRC 22 Max.)	
16	Upper Seat Ring	316 St. St. ASTM A479 TY 316 (HRC 22 Max.)	
		316 St. St. ASTM A479 TY 316 with Hardfaced Seat (HRC 22 Max.)	
17	Packing	PTFE Packing	
18	Lantern Ring (Optional)	304 St. St. ASTM A479 TY 304	
19	Packing Follower	304 St. St. ASTM A479 TY 304	
Ref. No.	Temperature Range	-29°C	232°C

- 1) Materials and processes in accordance with the requirements of NACE specification MR0103, 2003.  
Applications requiring compliance to MR0175, 2003 Rev. or ISO 15156 would require engineering review.
- 2) ASTM A638 Gr 660 will be substituted in applications when required due to the differential pressure.
- 3) Materials designated for these parts conform to NACE Class III (unexposed) bolting requirements.
- 4) Materials designated for these parts conform to NACE Class I or Class II (exposed) bolting requirement.
- 5) Zinc plating is mandatory for St. Steel construction only.

# Valve Dimensions

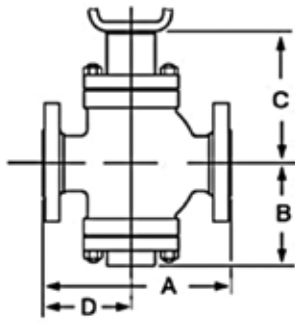

Flanged Ends

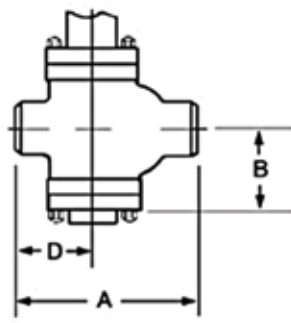

Socket Weld  
or Threaded Ends

10000 Series Dimensions (inches)

Valve Size		ASME Class 150 and equivalent PN				ASME Class 300 and equivalent PN				ASME Class 600 and equivalent PN				ASME Class 150-600 and equivalent PN	
inches	mm	RF		RTJ		RF		RTJ		RF		RTJ		Threaded & Socket Weld	
		A	D	A	D	A	D	A	D	A	D	A	D	A	D
0.75	20	7.24	3.66	-	-	7.64	3.86	8.11	4.09	8.11	4.09	8.11	4.09	6.02	2.87
1	25	7.24	3.66	7.76	3.90	7.76	3.90	8.27	4.13	8.27	4.13	8.27	4.13	6.02	2.87
1.5	40	8.74	4.09	9.25	4.33	9.25	4.33	9.76	4.57	9.88	4.65	9.88	4.65	7.99	3.70
2	50	10.00	4.61	10.51	4.88	10.51	4.88	11.10	5.20	11.26	5.24	11.38	5.31	9.25	4.13
3	80	11.73	5.51	12.24	5.75	12.52	5.87	13.11	6.18	13.27	6.26	13.39	6.30	-	-
4	100	13.90	6.57	14.37	6.81	14.49	6.89	15.12	7.20	15.51	7.36	15.63	7.44	-	-
6	150	17.76	7.64	18.11	7.87	18.62	8.07	19.25	8.39	20.00	8.74	20.12	8.82	-	-
8	200	21.38	8.54	21.89	8.82	22.40	9.06	22.99	9.37	24.02	9.88	24.13	9.92	-	-
10	250	24.61	9.96	25.12	10.24	26.02	10.67	26.65	10.98	27.99	11.65	27.87	11.61	-	-
12	300	28.74	11.30	29.25	11.57	30.24	12.09	30.87	12.36	32.01	12.91	32.13	12.99	-	-
14	350	33.50	12.99	34.02	13.27	35.00	13.74	35.63	14.06	36.77	14.61	36.89	14.69	-	-
16	400	35.39	15.71	35.87	15.94	37.01	16.50	37.64	16.81	39.02	17.24	39.13	17.32	-	-

Valve Size		ASME Class 150 – 600 and equivalent PN		
inches	mm	B	C (STD.Bonnet)	C (EB Bonnet)
0.75	20	4.49	5.67	9.72
1	25	4.49	5.67	9.72
1.5	40	5.39	6.02	10.67
2	50	5.98	7.20	11.42
3	80	7.80	9.29	13.11
4	100	8.11	9.49	13.74
6	150	11.18	12.60	18.03
8	200	13.39	14.69	20.00
10	250	14.80	16.42	22.60
12	300	17.80	19.80	25.98
14	350	21.50	24.09	32.60
16	400	22.28	26.10	34.61

# Valve Dimensions

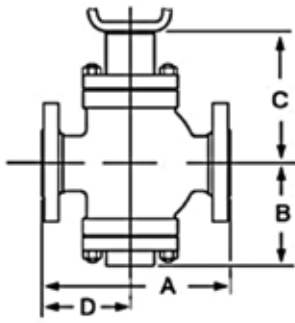

Flanged Ends

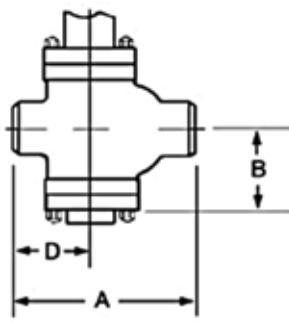

Socket Weld  
or Threaded Ends

## 10000 Series Dimensions (mm)

Valve Size		ASME Class 150 and equivalent PN				ASME Class 300 and equivalent PN				ASME Class 600 and equivalent PN				ASME Class 150-600 and equivalent PN	
mm	inches	RF		RTJ		RF		RTJ		RF		RTJ		Threaded & Socket Weld	
		A	D	A	D	A	D	A	D	A	D	A	D	A	D
20	0.75	184	93	-	-	194	98	206	104	206	104	206	104	153	73
25	1	184	93	197	99	197	99	210	105	210	105	210	105	153	73
40	1.5	222	104	235	110	235	110	248	116	251	118	251	118	203	94
50	2	254	117	267	124	267	124	282	132	286	133	289	135	235	105
80	3	298	140	311	146	318	149	333	157	337	159	340	160	-	-
100	4	353	167	365	173	368	175	384	183	394	187	397	189	-	-
150	6	451	194	460	200	473	205	489	213	508	222	511	224	-	-
200	8	543	217	556	224	569	230	584	238	610	251	613	252	-	-
250	10	625	253	638	260	661	271	677	279	711	296	708	295	-	-
300	12	730	287	743	294	768	307	784	314	813	328	816	330	-	-
350	14	851	330	864	337	889	349	905	357	934	371	937	373	-	-
400	16	899	399	911	405	940	419	956	427	991	438	994	440	-	-

Valve Size		ASME Class 150 – 600 and equivalent PN		
mm	inches	B	C (STD.Bonnet)	C (EB Bonnet)
20	0.75	114	144	247
25	1	114	144	247
40	1.5	137	153	271
50	2	152	183	290
80	3	198	236	333
100	4	206	241	349
150	6	284	320	458
200	8	340	373	508
250	10	376	417	574
300	12	452	503	660
350	14	546	612	828
400	16	566	663	879



# Valve Weights

Weights in (lbs)

Valve Size		ASME Class 150-600 and equivalent PN	ASME Class 150 and equivalent PN	ASME Class 300 and equivalent PN	ASME Class 600 and equivalent PN
inches	mm	Threaded & Socket Weld	Flanged		
0.75	20	40	79	79	90
1	25	44	86	86	99
1.5	40	44	106	110	119
2	50	51	150	159	174
3	80	110	245	256	269
4	100	192	304	309	335
6	150	364	514	529	595
8	200	668	798	825	959
10	250	1168	1349	1378	1497
12	300	1455	1698	1737	1898
14	350 <sup>(1)</sup>	-	-	-	-
16	400	2579	3016	3086	4198

1) Consult factory for weight data on 14" size.

Weights in (kg)

Valve Size		ASME Class 150-600 and equivalent PN	ASME Class 150 and equivalent PN	ASME Class 300 and equivalent PN	ASME Class 600 and equivalent PN
mm	inches	Threaded & Socket Weld	Flanged		
20	0.75	18	36	36	41
25	1	20	39	39	45
40	1.5	20	48	50	54
50	2	23	68	72	79
80	3	50	111	116	122
100	4	87	138	140	152
150	6	165	233	240	270
200	8	303	362	374	435
250	10	530	612	625	679
300	12	660	770	788	861
350 <sup>(1)</sup>	14	-	-	-	-
400	16	1170	1368	1400	1904

1) Consult factory for weight data on 14" size.

# Actuator Dimensions and Weights (in./lbs)

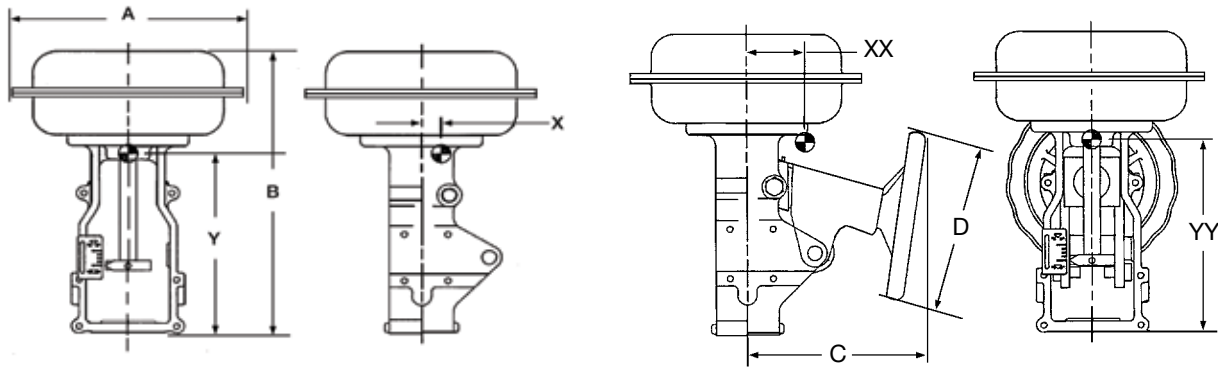

Shown with optional Handwheel

## Dimensions and Weights

Actuator Size	Actuator Dimensions (inches)				Weights (lbs.)	
	A	B (Model 88)	C	D	Standard	w/Handwheel
6	11.50	15.54 (17.52)	10.00	9.00	45	60
10	14.50	19.58 (21.54)	10.90	12.00	85	105
16	18.75	28.22 (30.79)	14.00	18.00	210	245
23	21.63	30.71 (33.27)	16.00	18.00	265	320

Actuator Removal Clearance = 6 inches

## Limit Stops (inches)

### Up Stop

Size	Model	Overall Height B
6	87	19.45
10		25.43
16		36.42
23		38.84
6	88	19.16
10		25.06
16		35.48
23		38.65

## Center of Gravity (inches)

### Without Handwheel

Size	X	Y
6	.19	9.75
10	.0	12.88
16	.13	18.50
23	.06	21.13

### With Handwheel

Size	XX	YY
6	1.25	9.13
10	0.88	12.00
16	1.38	16.75
23	1.38	19.00

### Down Stop

Size	Model	Overall Height B
6	87	19.80
10		25.98
16		37.20
23		39.90
6	88	19.74
10		25.85
16		37.46
23		40.33

# Actuator Dimensions and Weights (in./lbs)

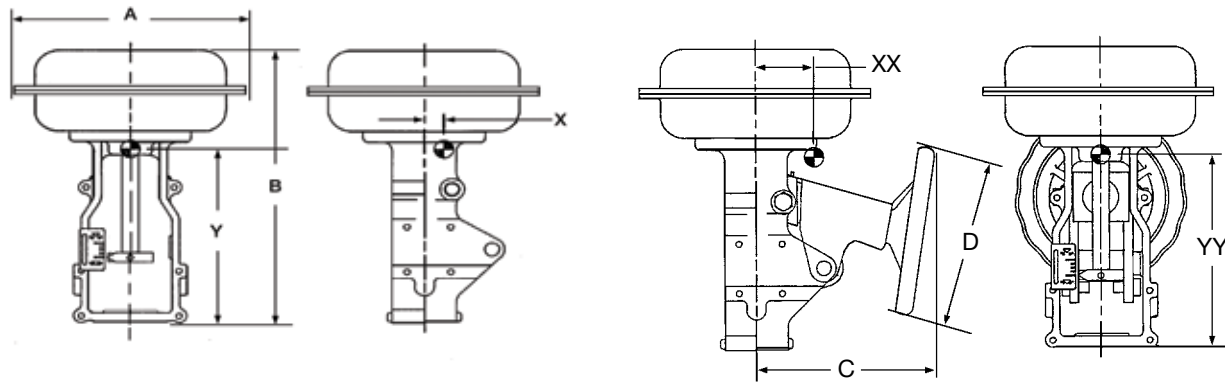

Shown with optional Handwheel

## Dimensions and Weights

Actuator Size	Actuator Dimensions (mm)				Weights (kg)	
	A	B (Model 88)	C	D	Standard	w/Handwheel
6	302	395 (445)	254	229	20	27
10	373	497 (547)	277	305	39	48
16	476	717 (782)	356	457	95	111
23	549	780 (845)	406	457	120	145

Actuator Removal Clearance = 152mm

## Limit Stops (mm)

Up Stop

Size	Model	Overall Height B
6	87	494
10		646
16		925
23		987
6	88	487
10		636
16		901
23		982

## Center of Gravity (mm)

Without Handwheel

Size	X	Y
6	5	248
10	0	327
16	3	470
23	2	537

With Handwheel

Size	XX	YY
6	32	232
10	22	305
16	35	425
23	35	483

Down Stop

Size	Model	Overall Height B
6	87	503
10		660
16		945
23		1014
6	88	501
10		657
16		952
23		1024

# DIRECT SALES OFFICE LOCATIONS

## BELGIUM

Phone: +32-2-344-0970  
Fax: +32-2-344-1123

## BRAZIL

Phone: +55-11-2146-3600  
Fax: +55-11-2146-3610

## CANADA

Ontario  
Phone: +905-335-3529  
Fax: +905-336-7628

## CHINA

Phone: +86-10-8486-4515  
Fax: +86-10-8486-5305

## FRANCE

Courbevoie  
Phone: +33-1-4904-9000  
Fax: +33-1-4904-9010

## GERMANY

Viersen  
Phone: +49-2162-8170-0  
Fax: +49-2162-8170-280

## INDIA

Mumbai  
Phone: +91-22- 8354790  
Fax: +91-22-8354791

## New Delhi

Phone: +91-11-2-6164175  
Fax: +91-11-5-1659635

## ITALY

Phone: +39-081-7892-111  
Fax: +39-081-7892-208

## JAPAN

Chiba  
Phone: +81-43-297-9222  
Fax: +81-43-299-1115

## KOREA

Phone: +82-2-2274-0748  
Fax: +82-2-2274-0794

## MALAYSIA

Phone: +60-3-2161-0322  
Fax: +60-3-2163-6312

## MEXICO

Phone: +52-5-310-9863  
Fax: +52-5-310-5584

## THE NETHERLANDS

Phone: +31-15-3808666  
Fax: +31-18-1641438

## RUSSIA

Veliky Novgorod  
Phone: +7-8162-55-7898  
Fax: +7-8162-55-7921

## Moscow

Phone: +7 495-585-1276  
Fax: +7 495-585-1279

## SAUDI ARABIA

Phone: +966-3-341-0278  
Fax: +966-3-341-7624

## SINGAPORE

Phone: +65-6861-6100  
Fax: +65-6861-7172

## SOUTH AFRICA

Phone: +27-11-452-1550  
Fax: +27-11-452-6542

## SOUTH & CENTRAL AMERICA AND THE CARIBBEAN

Phone: +55-12-2134-1201  
Fax: +55-12-2134-1238

## SPAIN

Phone: +34-93-652-6430  
Fax: +34-93-652-6444

## UNITED ARAB EMIRATES

Phone: +971-4-8139-200  
Fax: +971-4-8838-038

## UNITED KINGDOM

Wooburn Green  
Phone: +44-1628-536300  
Fax: +44-1628-536319

## UNITED STATES

Massachusetts  
Phone: +1-508-586-4600  
Fax: +1-508-427-8971

## Corpus Christi, Texas

Phone: +1-361-881-8182  
Fax: +1-361-881-8246

## Dresser Direct

## Deer Park, Texas

Phone: +1-281-884-1000  
Fax: +1-281-884-1010

## Dresser Flow Technologies

## Houston, Texas

Phone: +1-281-671-1640  
Fax: +1-281-671-1735

## California

Phone: +1-562-941-7610  
Fax: +1-562-941-7810

## About Dresser, Inc.

Dresser Inc. is a global leader in providing highly-engineered infrastructure products for the global energy industry.

Leading brand names within the Dresser portfolio include Dresser Wayne® retail fueling systems, Waukesha® natural gas-fired engines, Masoneilan® control valves, Consolidated® pressure relief valves, and ROOTS® blowers and rotary gas meters. The company has manufacturing and customer service facilities strategically located worldwide and a sales presence in more than 150 countries. [www.dresser.com](http://www.dresser.com).

## Dresser Masoneilan Dresser, Inc., Flow Technologies

10343 Sam Houston Park Drive  
Houston, Texas 77064 U.S.A  
T. +1-281-671-1640  
F. +1-281-671-1735  
E. [sales@masoneilan.com](mailto:sales@masoneilan.com)



© 2010 Dresser, Inc. All rights reserved.

## About Dresser Masoneilan

Dresser Masoneilan, headquartered in Houston, Texas, has been the leading global partner in process control valves and solutions for more than 100 years. A business segment of Dresser, Inc., the company delivers customized products, services and diagnostic solutions for oil and gas, process and power generation applications. [www.dresser.com](http://www.dresser.com)



[www.dresser.com](http://www.dresser.com)